

Pressure Gauges

Diaphragm Pressure gauge



YTP SERIES DIAPHRAGM PRESSURE GAUGE

YTP100ML

Description:

Diaphragm pressure gauges combine general pressure gauge with diaphragm body which are particularly suitable for high viscosity and high crystallisation fluids and in general every time corrosive gases, liquids are used, also in aggressive environments. With the open connecting flange option also for contaminated and viscous media

Application

- Chemical
- petrochemical
- power plants
- mining
- environmental technology
- food industry
- pharmaceutical industry and general plant construction

Specification

Nominal Size:

4.0"(100mm), 6.0"(150mm)

Accuracy: $\pm 1.0\%$, $\pm 1.6\%$, $\pm 2.5\%$

Pressure Range: 0-16mbar to 0-400mbar

0-0.6bar to 0-40bar

Working Temperature: -20°C ... 60°C

Case: Stainless steel with pressure vent

Ring: Stainless steel, Bayonet type

Connection: Stainless steel

Bourdon tube: Stainless steel, C-type or Helical type

Movement: Stainless steel

Dial: Aluminium, black lettering

Pointer: Aluminium, black

Window: Safety glass

Separator: Stainless steel

Gaskets/Filling cap/Safety cap: Neoprene or Silica gel



Tel: 0086-574-23688830
Fax: 0086-574-23688830
Email: info@st-meter.com
Web: <http://www.st-meter.com>

Cixi Sito machinery Co.LTD.
West Section Gongye Road, Xinpu Town,
Cixi City, Ningbo, Zhejiang Province, China

Pressure Gauges

Diaphragm Pressure Gauge



Options

Separator option: open flange connection, clamp connection, threaded connection: special connection, like locating at 3,9 or 12 o'clock; Customize range, scale or logo.

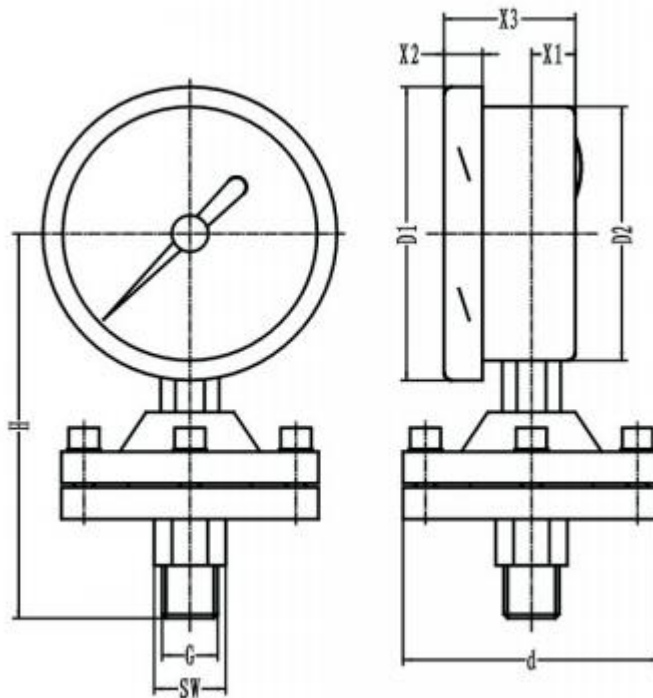

Dimensions in mm											
Types	Nom.size	D1	D2	X1	X2	X3	d	H	G	SW	Weight
100mm	100	110.5	99	15.5	14	49	97	147	1/2" NPT	Hexagon 24	2.2

Tel:0086-574-23688830
Fax:0086-574-23688830
Email:info@st-meter.com
Web:http://www.st-meter.com

Cixi Sito machinery Co.LTD.
West Section Gongye Road,Xinpu Town,
Cixi City,Ningbo,Zhejiang Province,China