

# Pressure Gauges

## Process Pressure gauge



### SS SERIES PROCESS PRESSURE GAUGE

SS113

#### Description:

Process pressure gauges are suitable for measurements of corrosive and non-obstructive liquids, and gases, and not attack copper alloy parts.

#### Application

- General industrial

#### Specification

Nominal Size:

4.5"(113mm)

Accuracy:  $\pm 1.0\%$ ,  $\pm 1.6\%$

Pressure Range: -1...0bar to 0...400bar

Working Temperature: -20°C...60°C

Case: SS304 polished

Ring: Stainless steel

Connection: Brass

Thread: 1/4"NPT and requested

Bourdon tube: Phosphor bronze, C-type or Helical type

Movement: Brass

Dial: Aluminium, White, black lettering

Pointer: Aluminium, black

Window: PC

#### Options

Customize range, scale or logo; connection thread, restrictor screw etc.



Tel: 0086-574-23688830  
Fax: 0086-574-23688830  
Email: [info@st-meter.com](mailto:info@st-meter.com)  
Web: <http://www.st-meter.com>

Cixi Sito machinery Co.LTD.  
West Section Gongye Road, Xinpu Town,  
Cixi City, Ningbo, Zhejiang Province, China

# Pressure Gauges

## Process Pressure Gauge

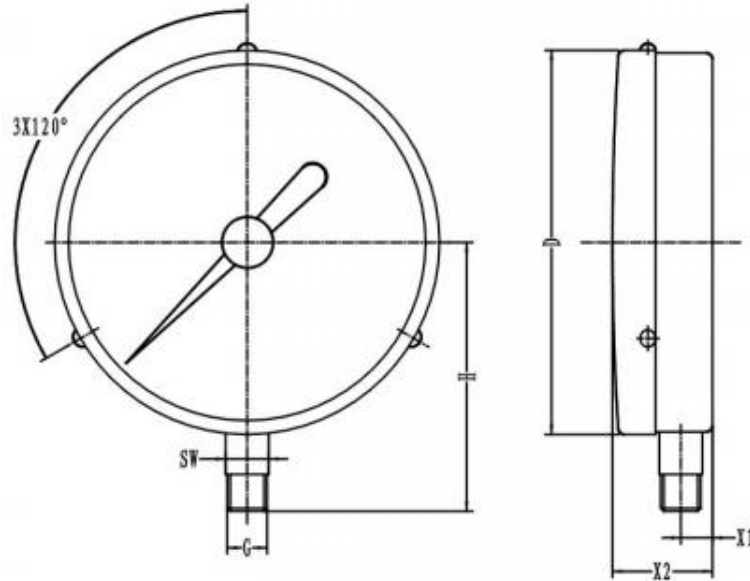

Bottom Connection

Dimensions in mm								
Types	X1	X2	D	H	D1	G	SW	Weight
113mm	10.5	35.5	125	89	136.5	1/4NPT	14	0.32

Tel:0086-574-23688830  
Fax:0086-574-23688830  
Email:info@st-meter.com  
Web:http://www.st-meter.com

Cixi Sito machinery Co.LTD.  
West Section Gongye Road,Xinpu Town,  
Cixi City,Ningbo,Zhejiang Province,China